

CARACTERISTICAS TECNICAS

- Caja de aluminio inyectado con amplia capacidad de disipación de calor
- Corona de bronce fosforoso al níquel
- Sin fin cementado con flanco de hélices rectificadas
- 4 rodamientos ampliamente dimensionados
- Sellado: con retenes de doble labio y anillos o ring en todas las tapas y bridas
- Lubricación de por vida provisto con aceite Sintético
- Múltiples posibilidades de fijación
- Montaje directo sobre motores Normalizados con bridas B14 y B5
- Relaciones desde 1:7.5 a 1:10.000
- Entrega inmediata
- Stock permanente

Dimensiones Generales

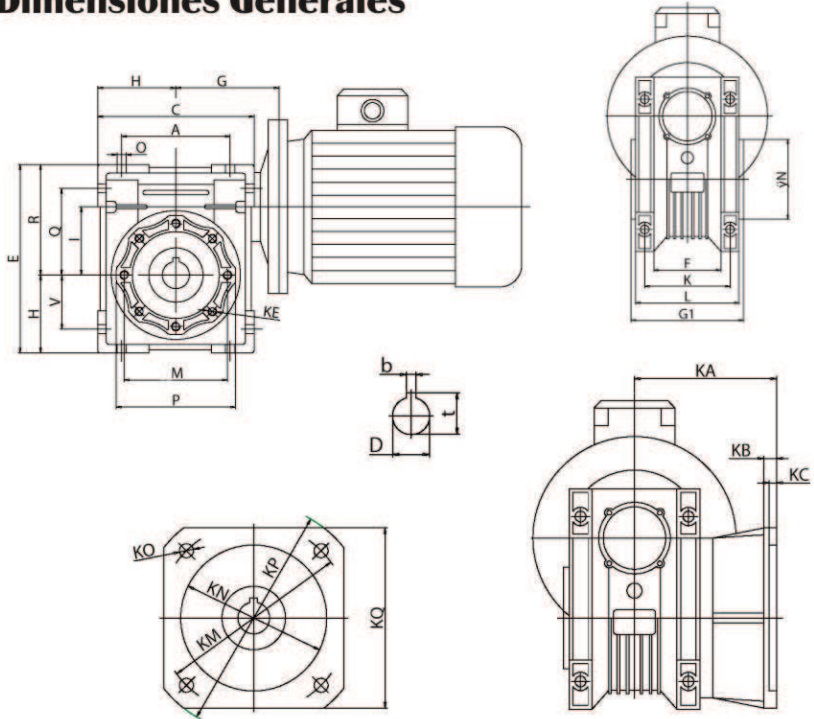

Tamaño	A	C	D(H7)	E	F	G	G1	H	I	L	M	N(h8)	O	P	Q
25	45	70	11	83	22	45	42	35	35.5	37	45	45	6.5	45	35
30	54	80	14	97	32	55	63	40	30	56	65	55	6.5	75	44
40	70	100	18	121.5	43	70	78	50	40	71	75	60	6.5	87	55
50	80	120	25	144	49	80	92	60	50	85	85	70	8.5	100	64
63	100	144	25	174	67	95	112	72	63	103	95	80	8.5	110	80
75	120	172	28	205	72	112.5	120	86	75	112	115	95	11	140	93
90	140	208	35	238	74	129.5	140	103	90	130	130	110	13	160	102
110	170	252.5	42	295	-	160	155	127.5	110	144	165	130	14	200	125
130	200	292.5	45	335	-	180	170	147.5	130	155	215	180	16	250	140

Tamaño	R	V	K	KA	KB	KC	KE	KM	KN	KO	KP	KQ	b	t	Peso Kg
25	48	22.5	35	45	6	3	M6x11(4)	65	40	5	75	70	4	13	0.9
30	57	27	44	54.5	6	4	M6x11(4)	68	50	6.5(4)	80	70	5	16.3	1.2
40	71.5	35	60	67	7	4	M8x8(4)	87	60	9(4)	110	95	6	20.8	2.3
50	84	40	70	90	9	5	M8x10(4)	90	70	11(4)	125	110	8	28.3	3.5
63	102	50	85	82	10	6	M8x14(8)	150	115	11(4)	180	142	8	28.3	6.2
75	119	60	90	111	13	6	M8x14(8)	165	130	14(4)	200	170	8	31.3	9
90	135	70	100	111	13	6	M10x18(8)	175	152	14(4)	210	200	10	38.3	13
110	167.5	85	115	131	15	6	M10x18(8)	230	170	14(8)	280	260	12	45.3	35
130	187.5	100	120	140	15	6	M12x21(8)	255	180	16(8)	320	290	14	48.8	48

Ejes de Salida ES - simple /ED - doble

Tamaño	D(h6)	B	B1	L	L1	G1	f
25	11	23	25.5	81	101	50	-
30	14	30	32.5	102	128	63	M6
40	18	40	43	128	164	78	M6
50	25	50	53.5	153	199	92	M10
63	25	50	53.5	173	219	112	M10
75	28	60	63.5	192	247	120	M10
90	35	80	84.5	234	309	140	M12
110	42	80	84.5	249	324	155	M16
130	45	80	85	265	340	170	M16

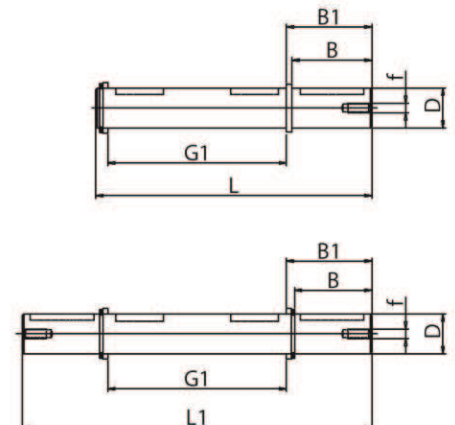

ROSARIO TRANSMISIONES

Bv. Segui 2707-Rosario-Tel. 0341 434 0271 Cel. 0341 156 132199
e-mail: cristian@rtransmisiones.com.ar

ROSARIO TRANSMISIONES

Bv. Segui 2707-Rosario-Tel. 0341 434 0271 Cel. 0341 156 132199
e-mail: cristian@rtransmisiones.com.ar

Relación Nominal	RPM de salida	Velocidad de entrada n1=1500 rpm									
		I	n2(rpm)	NMRV-25	NMRV-30	NMRV-40	NMRV-50	NMRV-63	NMRV-75	NMRV-90	NMRV-110
7.5	200	Hp	0.12	0.25	0.5	1	2	4	5.5	10	12.5
		M2	0.14	0.90	2	3.17	6.80	12.51	17.67	32.20	40.28
		η	0.85	0.85	0.89	0.89	0.87	0.87	0.90	0.90	0.90
10	150	Hp	0.12	0.3	0.75	1	2	4	5.5	10	12.5
		M2	0.5	1.17	3.05	4.11	9.02	16.80	23.27	42.47	53.11
		η	0.85	0.82	0.85	0.86	0.87	0.88	0.89	0.89	0.89
15	100	Hp	0.12	0.25	0.5	1	2	3	4	7.5	10
		M2	0.73	1.37	2.84	5.88	11.84	17.78	24.56	46.19	62.3
		η	0.85	0.77	0.79	0.82	0.83	0.83	0.86	0.86	0.87
20	75	Hp	0.12	0.25	0.5	1	2	3	4	7.5	10
		M2	0.85	1.74	3.69	7.51	15.40	23.38	31.94	60.90	81.16
		η	0.82	0.73	0.77	0.79	0.81	0.82	0.84	0.85	0.85
25	60	Hp	0.12	0.25	0.34	0.75	1	1.75	3	5.5	10
		M2	1.15	2.02	2.95	6.67	9.24	16.33	29.30	55.15	100.26
		η	0.80	0.68	0.73	0.74	0.77	0.78	0.82	0.84	0.84
30	50	Hp	0.12	0.16	0.34	0.75	1	1.5	3	5.5	7.5
		M2	1.26	1.46	3.43	7.66	10.17	16.23	33.02	62.17	85.94
		η	0.80	0.64	0.70	0.71	0.71	0.76	0.77	0.79	0.8
40	37.5	Hp		0.16	0.34	0.5	1	1.5	2	4	5.5
		M2		1.80	4.19	6.24	13.35	20.62	28.56	58.89	81.93
		η		0.59	0.65	0.65	0.70	0.72	0.75	0.77	0.78
50	30	Hp		0.12	0.25	0.5	0.75	1	2	3	5.5
		M2		1.54	3.70	6.91	11.74	16.42	34.44	52.50	97.16
		η		0.54	0.62	0.58	0.66	0.69	0.72	0.73	0.74
60	25	Hp		0.12	0.16	0.34	0.75	1	1.5	3	4
		M2		1.16	2.66	5.71	13.48	18.66	29.69	61.88	82.50
		η		0.51	0.58	0.59	0.63	0.65	0.69	0.72	0.72
80	18.7	Hp		0.08	0.16	0.25	0.5	0.75	1	2	3
		M2		1.37	3.19	5.11	10.81	17.23	24.05	49.60	76.98
		η		0.45	0.52	0.53	0.56	0.60	0.63	0.65	0.67
100	15	Hp			0.12	0.16	0.5	0.75	1	1.5	2
		M2			2.70	3.63	11.38	17.18	25.20	44.14	60.16
		η			0.47	0.48	0.48	0.48	0.53	0.62	0.63

n2: rpm en eje de salida

Hp: Potencia del motor

M2(kgm): Momento de torsión máxima en el eje de salida

η : Rendimiento mecánico

Nota: Los valores de rpm (n2) indicados corresponden a la velocidad nominal del motor.

Brazo de reacción BR

Tamaño	A	B	C	D	E	F	G	H	I
25	70	35	119	45	55	7	4	8	14
30	85	38	138	55	65	7	4	8	14
40	100	44	162	60	75	7	4	10	14
50	100	50	168	70	85	9	4	10	14
63	150	55	223	80	95	9	6	10	14
75	200	70	300	95	115	9	6	20	25
90	200	80	310	110	130	11	6	20	25
110	250	100	385	130	165	11	6	25	30
130	250	125	410	180	215	14	6	25	30

