

MODELO	RELACION	HP	ACEITE	PESO
<b>ML 150</b>	<b>1 : 1,5</b>	<b>45</b>	<b>SAE 140</b>	<b>42 KGS.</b>

### DIMENSIONES GENERALES

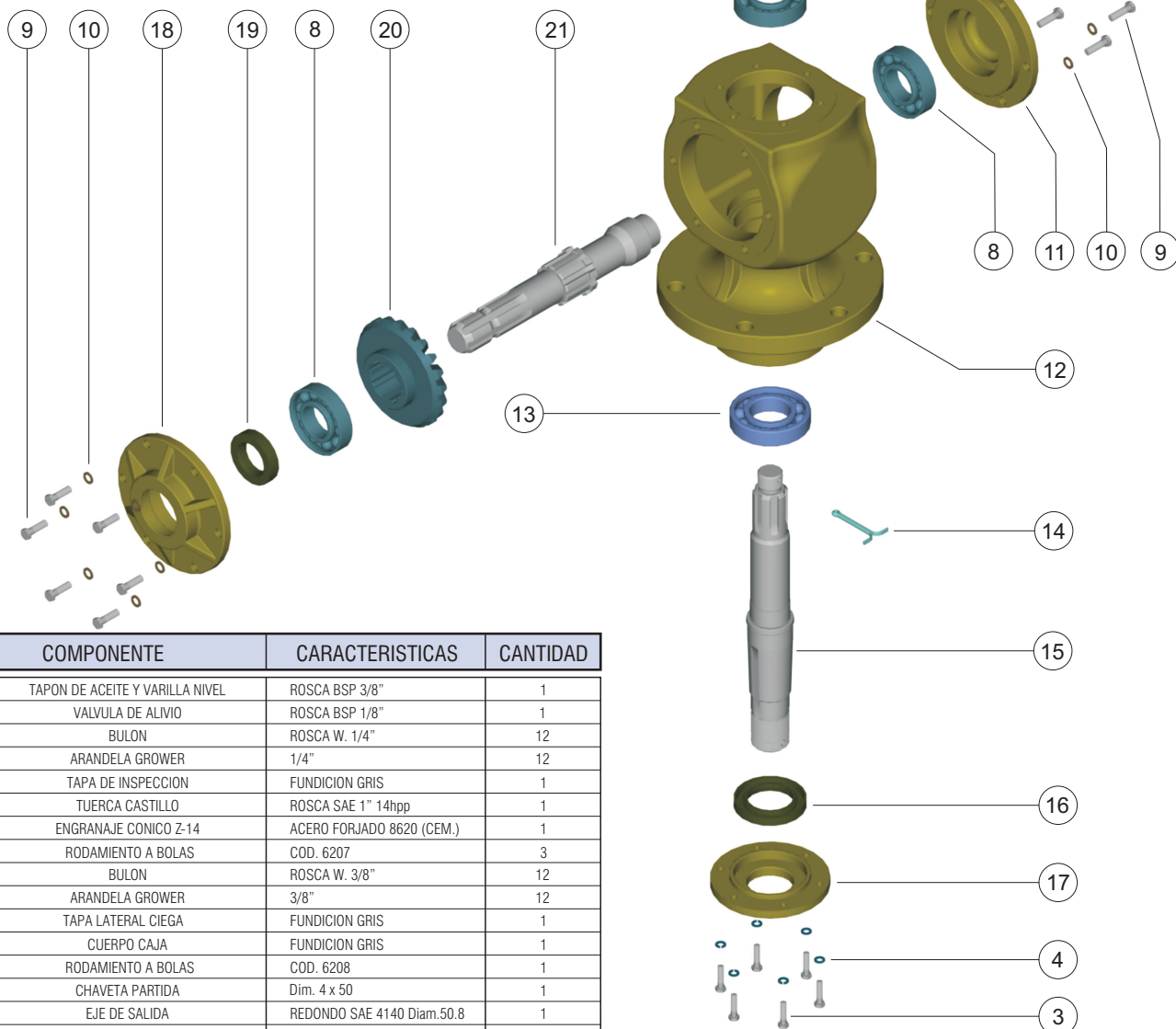
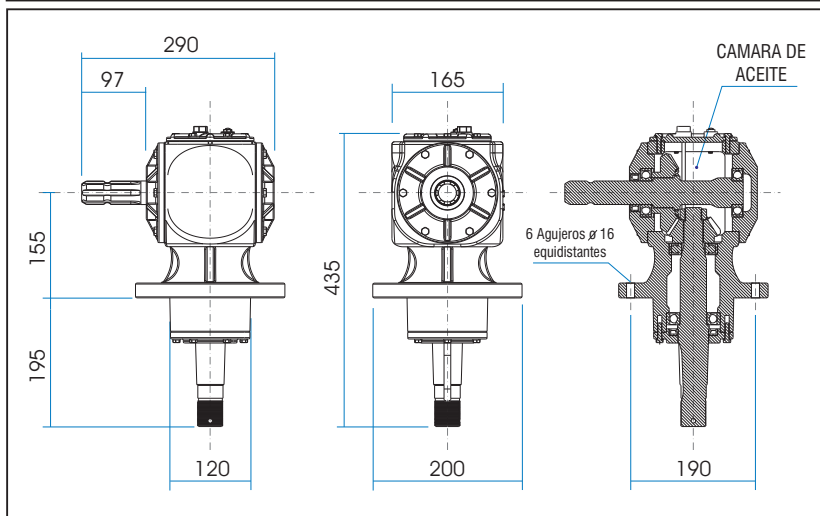

Nº	COMPONENTE	CARACTERISTICAS	CANTIDAD
1	TAPON DE ACEITE Y VARILLA NIVEL	ROSCA BSP 3/8"	1
2	VALVULA DE ALIVIO	ROSCA BSP 1/8"	1
3	BULON	ROSCA W. 1/4"	12
4	ARANDELA GROWER	1/4"	12
5	TAPA DE INSPECCION	FUNDICION GRIS	1
6	TUERCA CASTILLO	ROSCA SAE 1" 14hpp	1
7	ENGRANAJE CONICO Z-14	ACERO FORJADO 8620 (CEM.)	1
8	RODAMIENTO A BOLAS	COD. 6207	3
9	BULON	ROSCA W. 3/8"	12
10	ARANDELA GROWER	3/8"	12
11	TAPA LATERAL CIEGA	FUNDICION GRIS	1
12	CUERPO CAJA	FUNDICION GRIS	1
13	RODAMIENTO A BOLAS	COD. 6208	1
14	CHAVETA PARTIDA	Dim. 4 x 50	1
15	EJE DE SALIDA	REDONDO SAE 4140 Diam.50.8	1
16	RETEN	Dim. 72 x 45 x 10	1
17	TAPA INFERIOR	FUNDICION GRIS	1
18	TAPA DE ENTRADA	FUNDICION GRIS	1
19	RETEN	Dim. 56 x 35 x 12	1
20	ENGRANAJE CONICO Z-21	ACERO FORJADO 8620 (CEM.)	1
21	EJE DE ENTRADA	REDONDO SAE 4140 Diam. 44.45	1

**ROSARIO**  
**TRANSMISIONES**

MODELO	RELACION	HP	ACEITE	GRASA	PESO
<b>ML 200</b>	<b>1 : 1,5</b>	<b>65</b>	<b>SAE 140</b>	<b>LITIO</b>	<b>50 KGS.</b>

**DIMENSIONES GENERALES**

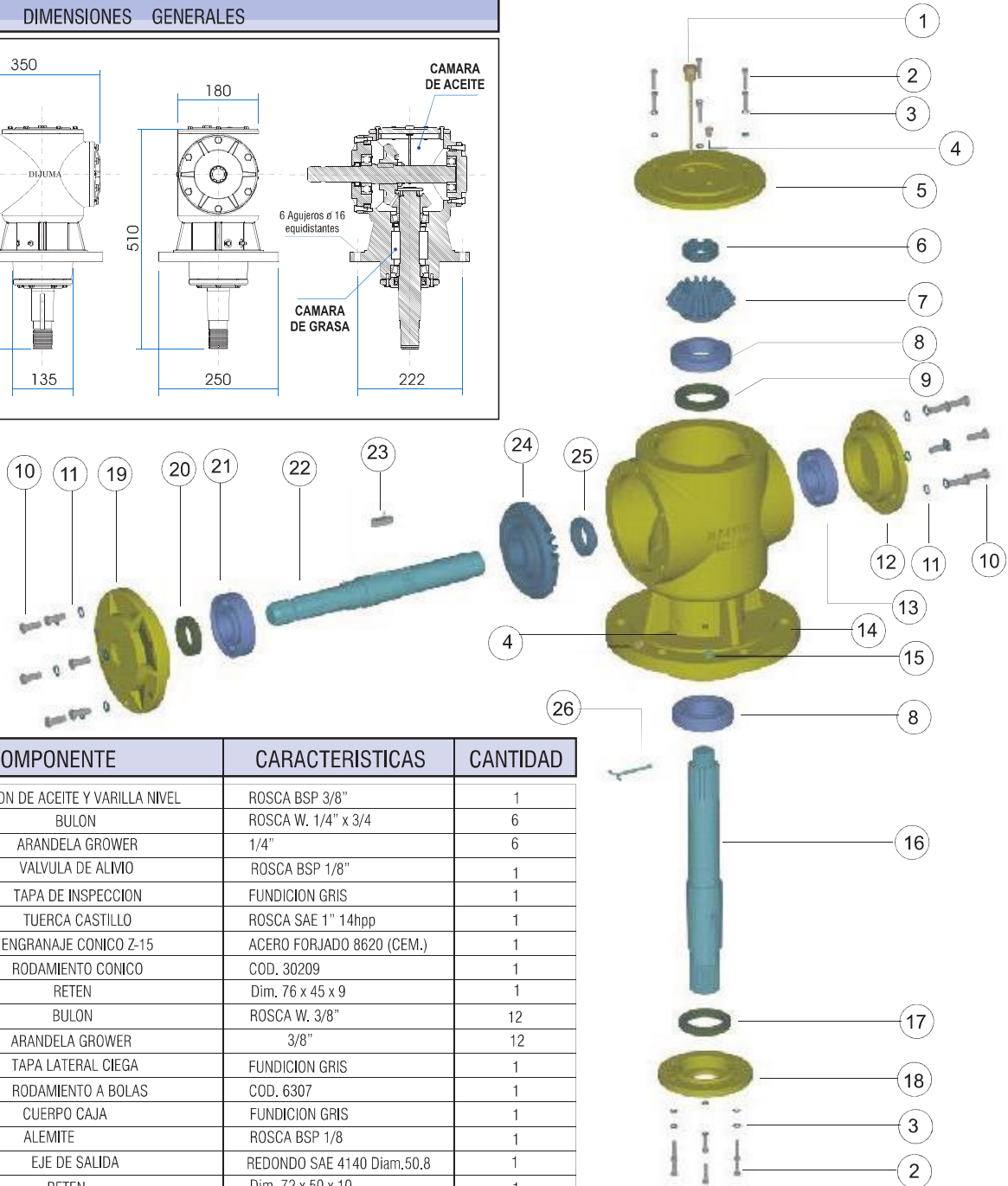
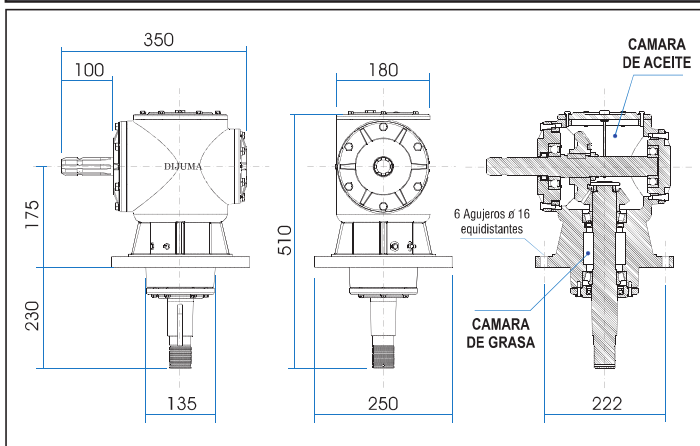

Nº	COMPONENTE	CARACTERISTICAS	CANTIDAD
1	TAPON DE ACEITE Y VARILLA NIVEL	ROSCA BSP 3/8"	1
2	BULON	ROSCA W. 1/4" x 3/4	6
3	ARANDELA GROWER	1/4"	6
4	VALVULA DE ALIVIO	ROSCA BSP 1/8"	1
5	TAPA DE INSPECCION	FUNDICION GRIS	1
6	TUERCA CASTILLO	ROSCA SAE 1" 14hpp	1
7	ENGRANAJE CONICO Z-15	ACERO FORJADO 8620 (CEM.)	1
8	RODAMIENTO CONICO	COD. 30209	1
9	RETEN	Dim. 76 x 45 x 9	1
10	BULON	ROSCA W. 3/8"	12
11	ARANDELA GROWER	3/8"	12
12	TAPA LATERAL CIEGA	FUNDICION GRIS	1
13	RODAMIENTO A BOLAS	COD. 6307	1
14	CUERPO CAJA	FUNDICION GRIS	1
15	ALEMITE	ROSCA BSP 1/8	1
16	EJE DE SALIDA	REDONDO SAE 4140 Diam.50,8	1
17	RETEN	Dim. 72 x 50 x 10	1
18	TAPA INFERIOR	FUNDICION GRIS	1
19	TAPA DE ENTRADA	FUNDICION GRIS	1
20	RETEN	Dim. 56 x 35 x 12	1
22	EJE DE ENTRADA	REDONDO SAE 4140 Diam 44.45	1
23	CHAVETA PLANA	Dim. 3/8 X 35	1
24	ENGRANAJE CONICO Z 23	ACERO FORJADO 8620 CEM	1
25	TUERCA DE AJUSTE	ROSCA SAE diam 40 x 18 hpp	1
26	CHAVETA PARTIDA	Dim. 5 x 50	1



Bv. Segui 2707-Rosario-Tel. 0341 434 0271 / 431 9293 / 156 132199  
e-mail: cristian@rtransmisiones.com.ar leonardo@rtransmisiones.com.ar

MODELO	RELACION	HP	ACEITE	PESO
MLT 3000	1 : 1	110	SAE 140	43 Kg.

## APLICACIONES:

- DESMALEZADORAS
- TRITURADORAS
- TRANSMISIONES

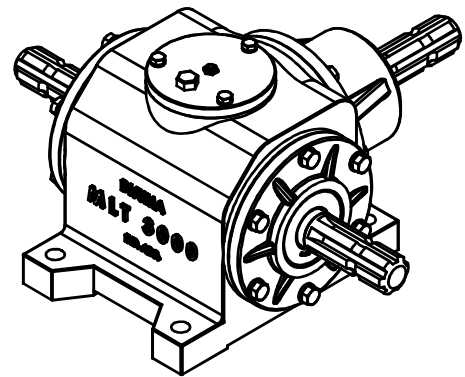
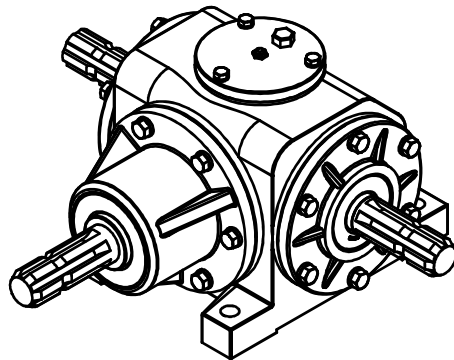

## DIMENSIONES GENERALES

